

Notice: This drawing contains proprietary information and shall not be used or reproduced or its contents disclosed in whole or in part, without the prior written consent of the Mann Teknik AB

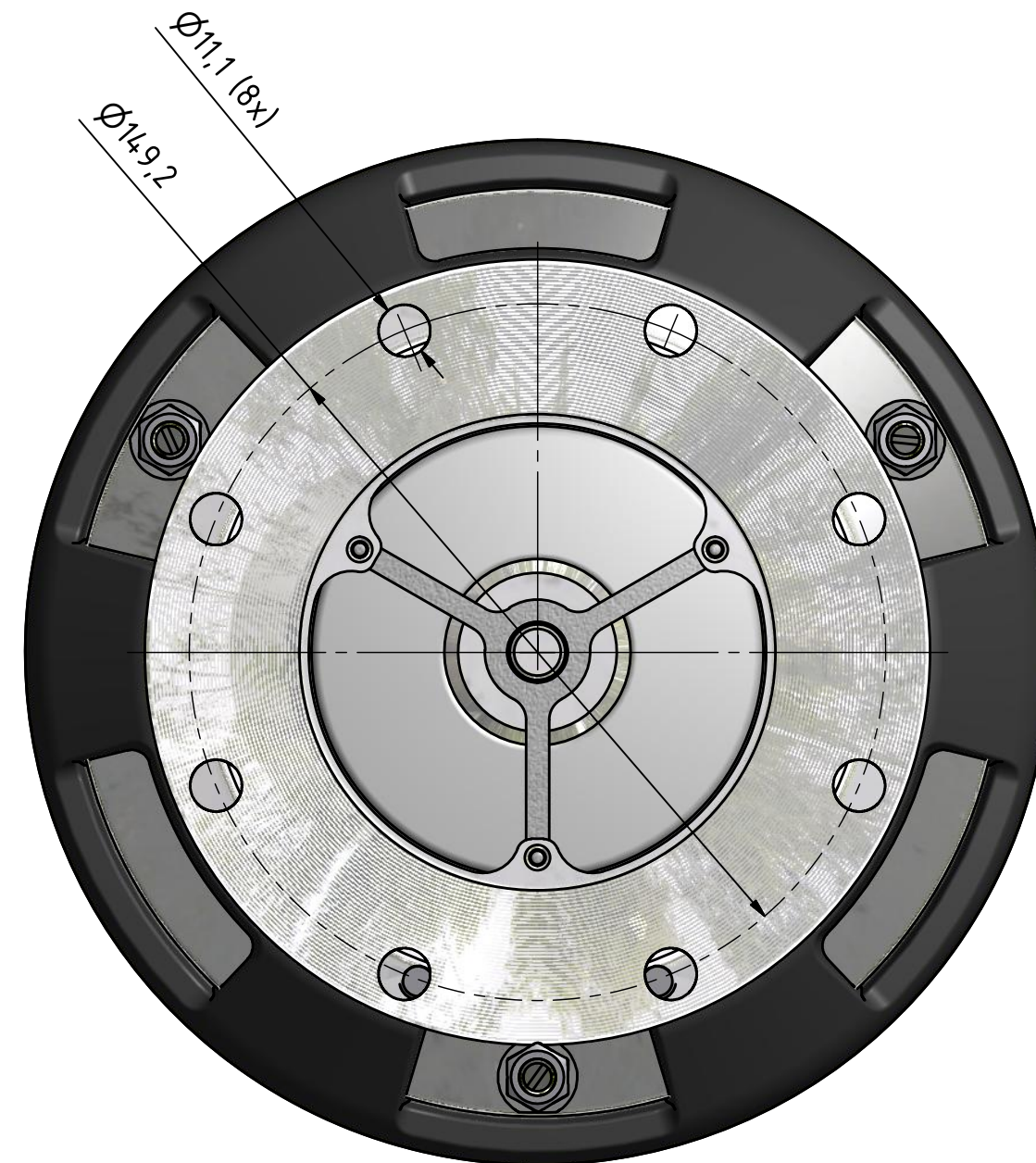
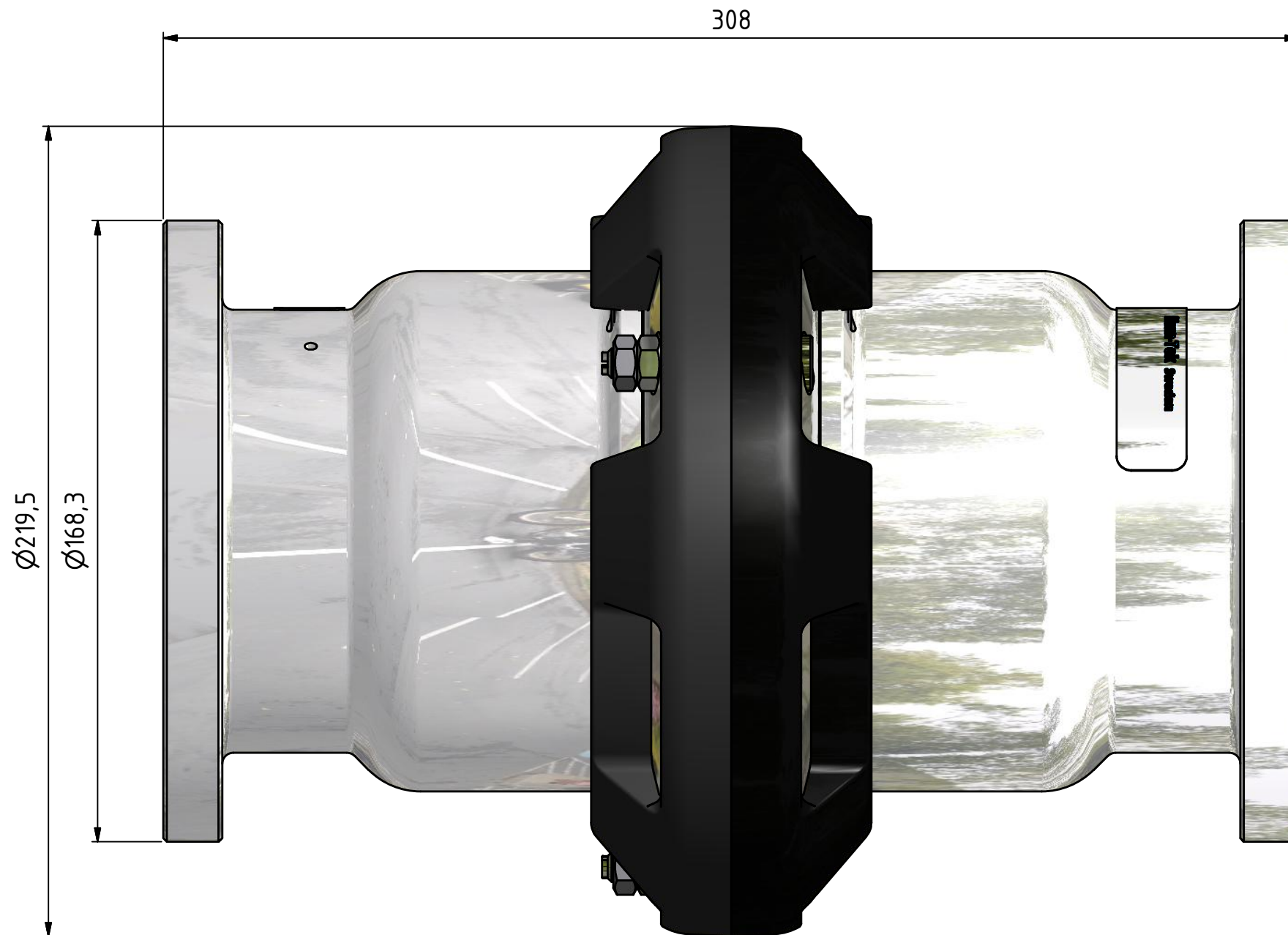

| NO. | Revision comprises | Date | Sign. | Appr by |
|-----|--------------------|------|-------|---------|
|     |                    |      |       |         |

|  |                                 |                    |  |                     |
|--|---------------------------------|--------------------|--|---------------------|
| Detail No:   | Material                        | Ämne/Blank         | Ytbeh./Treatment   | Vikt/Weight         |
| <b>Mann</b><br>Tek   | Designed/drawn by<br>G. Kopplin | Scale:<br>1:1,5    | Dimension with no tolerances acc to<br>Machined SS-ISO 2768-1 medium<br>Weld Forge SS-ISO 2768-1 coarse<br>Surface roughness ISO 1302<br>Form & position tol SS ISO 1101 |                     |
|  | Checked<br>P. Nyberg            | Date<br>2009-10-14 |  |                     |
|  | Approved<br>T. Mann             |                    |  |                     |
| <b>Industrial Break-Away 4"</b><br><b>Flange 4" T.T.M.A.</b> |                                 |                    | Data nr./Comp No.<br>N568D1101E  | Blad/Sheet<br>1 / 1 |
|  |                                 |                    | Drawing No.<br><b>N568D1101E-1</b>   | Rev.                |