



**25 Ton Ram Operating Instructions –**  
*External Swaging*

**25 Ton Ram Operating Instructions –**  
*External Swaging of  
RSTxxxNOS Stems*

**25 Ton Ram Operating Instructions –**  
*External Swaging of  
Cam & Groove Fittings*

**25 Ton Ram Operating Instructions –**  
*Converting from Swaging  
to Internal Expansion*

**25 Ton Ram Operating Instructions –**  
*Internal Expansion of  
Steel and Stainless Steel Stems*

**25 Ton Ram Operating Instructions –**  
*Internal Expansion of  
Holedall H-520 Series Couplings*

**Product Updates / Notes**

**Sample Forms**

**Parts Lists and Warranties**



*The Right Connection®*

## 25 Ton Ram Operating Instructions

### *Section 1*

### ***External Swaging of Standard Holedall***



**Dixon**

800 High Street • Chestertown, MD 21620

ph: 877•963•4966 fax: 800•283•4966

***dixonvalve.com***

1

Before you begin, make sure the ram is fully retracted. Install **25PUSH400** (also referred to as the pusher hat) onto the main pusher plate. This is required for all standard Holedall fittings. Make sure the bolt holes align with the ½" bolts and wing nuts supplied

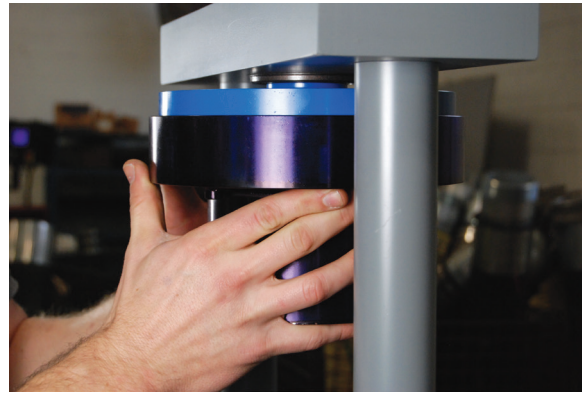

2

Insert Die Holders into the Die Bed Plate as follows:

- a) **DH9-004** - Master Die Holder to hold all of the other die holders.
- b) **DH9-004-1** - Die Holder for 4" I.D. hoses only.
- c) **DH6-003** - Die Holder for 1¼" - 3" I.D. hose dies (fits into **DH9-004**).
- d) **DH3-001** - Die Holder for ¼" - 1" I.D. hose dies (**DH6-003** and **DH9-004** also required).

Secure the Die Holders with the tie down bars supplied.



3

Select the proper pusher for the I.D. of the hose. The pusher should be the same size as the stem. There are separate pushers required for 1¼" through 3" I.D. hose. Insert the selected pusher into the **25PUSH400** and secure it with the set screws provided.

For Unirange (1" and below) remove the **25PUSH400** and install the **25PUSH100** as well as the correct pusher for the size of Unirange coupling. There is a separate pusher for each Unirange assembly size.

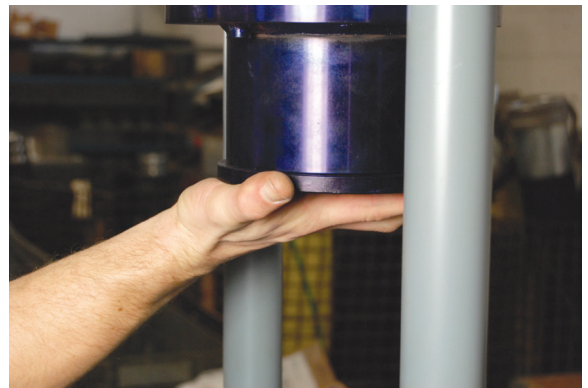

4

Accurately measure the hose O.D. with a diameter tape. Each end of the hose should be measured to guarantee the correct ferrule and die selection.

Select the correct ferrule and die based upon the hose free O.D. just measured from the die chart.



5



Ensuring that the hose end is cut square, chamfer the I.D. of the hose  $\frac{1}{8}$ " at a 45° angle (this is to relieve hose end flare of rubber tube hoses during stem insertion). If the hose is to be static grounded, follow hose manufacturers procedure for proper static grounding.

6

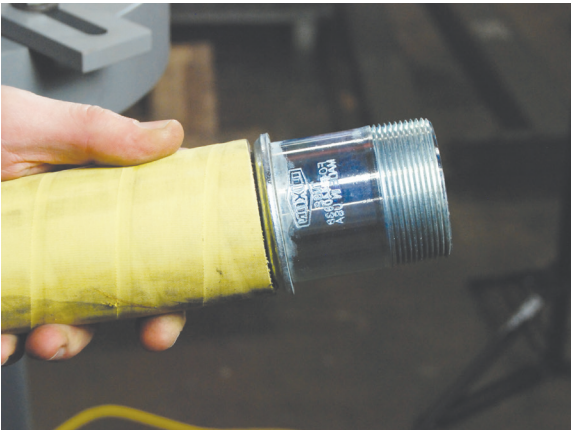

Lubricate the I.D. of the hose and the O.D. of the stem with Dixon® lubricant or equivalent. Insert the stem all the way into the hose until the ring on the stem comes in contact with the end of the hose.

7



Slide the ferrule over the stem and over the O.D. of the hose until the turned over portion of the ferrule rests on the ring of the stem.

8a



Lubricate the outside of the ferrule with Crisco® (recommended) or a high viscosity oil or heavy duty grease.

8b

Lubricate the I.D. of the die halves with Crisco® (recommended) or a high viscosity oil or heavy duty grease.



9

Insert the hose fitting assembly through the bottom of the ram (between the die holders) far enough to allow room to install the die halves into the die holder. After installing the die halves, push the hose up into the pusher until the ferrule comes in contact with the pusher.



10

"Jog" the ram by quickly depressing and releasing the "on" button on the remote control switch, (or by depressing the foot pedal) until the ferrule enters the opening of the die. Let the ferrule enter the die slowly, making sure the end of the ferrule does not hit the top of the die. Make sure that the stem and ferrule are held securely against the pusher until the swaging process has begun.

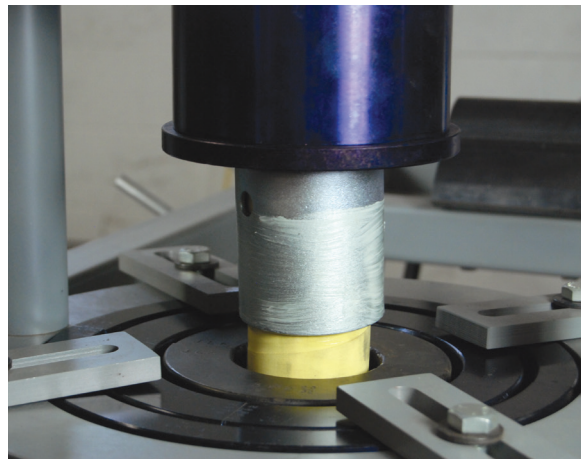

11a

To complete the swaging process, depress and hold the "on" switch of the remote control unit (or depress the foot pedal). Once the ferrule has entered the die and started to be reduced (approximately 1/3 of the way), it will no longer need the operator to keep it seated into the pusher. Continue the swage until the pusher meets the die, or until the gauge reads 10,000 PSI.

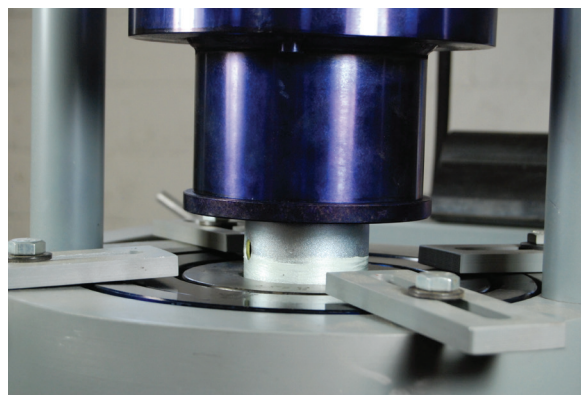

## 11b

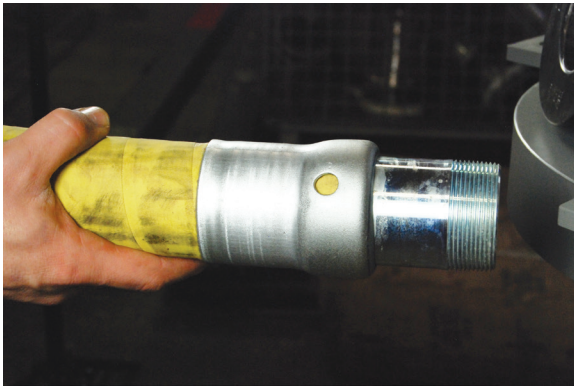

Note: If the gauge reads 10,000 PSI before swaging is complete, stop. The ferrule or die used for that hose end may be incorrect. Contact Dixon® for further assistance.

Dixon® recommends that all hose assemblies be tested as recommended by the Association for Rubber Products Manufacturer's (ARPM) [ARPMINC.com](http://ARPMINC.com).

# Typical Setup - 25 Ton Ram, External Swaging

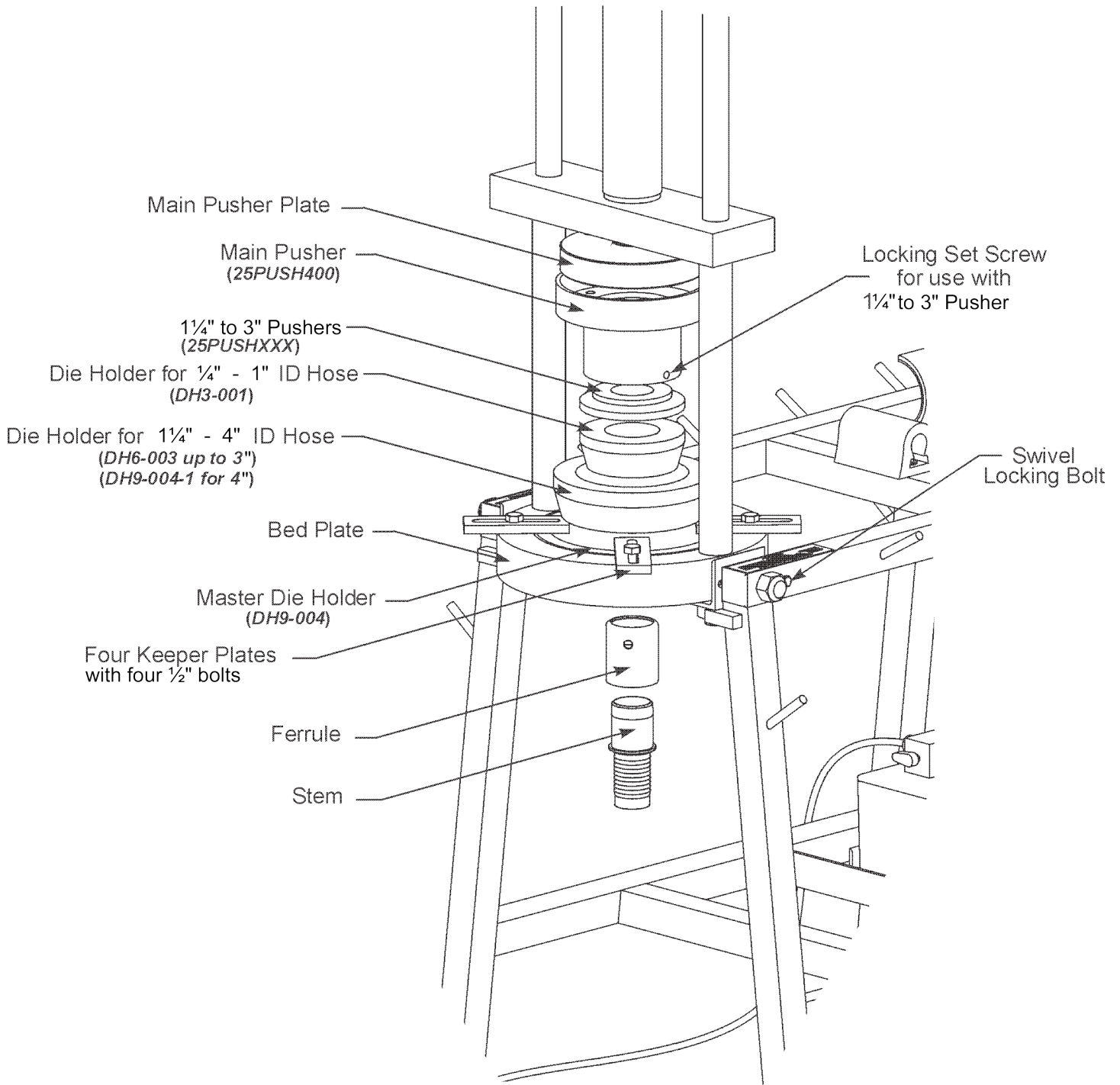





*The Right Connection®*

## 25 Ton Ram Operating Instructions

### *Section 2*

## ***External Swaging of RSTxxxNOS Stems***



**Dixon**

800 High Street • Chestertown, MD 21620

ph: 877•963•4966 fax: 800•283•4966

***dixonvalve.com***

1

Before you begin, make sure the ram is fully retracted. Install **25PUSH400** (also referred to as the pusher hat) onto the main pusher plate. Install the **MISCPUSH** into the **25PUSH400** and secure with set screw.



2

Insert Die Holders into the Die Bed Plate as follows:

- a) **DH9-004** - Die holder. This is necessary to hold all of the other die holders.
- b) **DH6-003** - Die holder for 1¼" - 3" I.D. hose dies.

Secure the die holders with the keeper plates supplied.



3

Accurately measure the hose O.D. with a diameter tape. Each end of the hose should be measured to guarantee the correct ferrule and die selection.

Select the correct ferrule and die based upon the hose free O.D. just measured, from the die chart.

Make sure the hose end is cut square. If the hose is to be static grounded, follow hose manufacturers procedure for proper static grounding.



4

Slide the ferrule onto the hose. Place a mark on the hose at the end of the ferrule. Move the ferrule ⅛" from the mark just made towards the end of the hose. Place a second mark on the hose at the end of the ferrule.

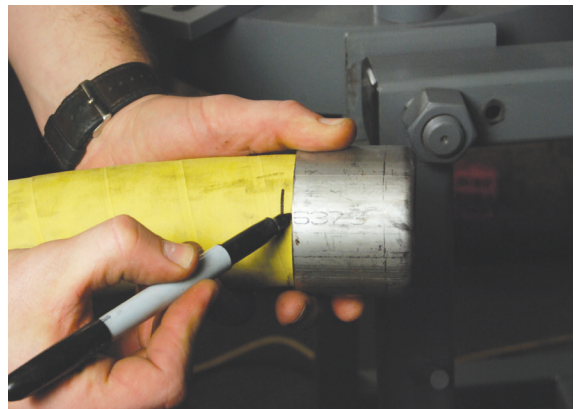

5

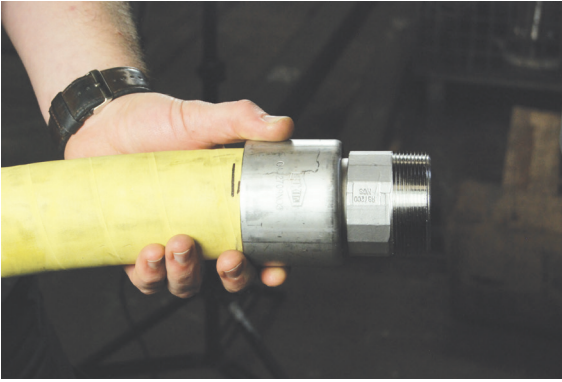

Lubricate the O.D. of the stem and the I.D. of the hose with Dixon® lubricant or equivalent.

Insert the end of the fitting into hose. Assemble ferrule onto stem by sliding turned over portion of ferrule past notched section of the stem collar. Rotate the ferrule 90° (¼ turn). With ferrule and stem engaged, continue installing stem until ferrule reaches the second mark made on the hose.

6a



Lubricate the outside of the ferrule with Crisco® (recommended) or a high viscosity oil or heavy duty grease.

6b



Lubricate the I.D. of die halves with Crisco® (recommended) or a high viscosity oil or heavy duty grease.

7

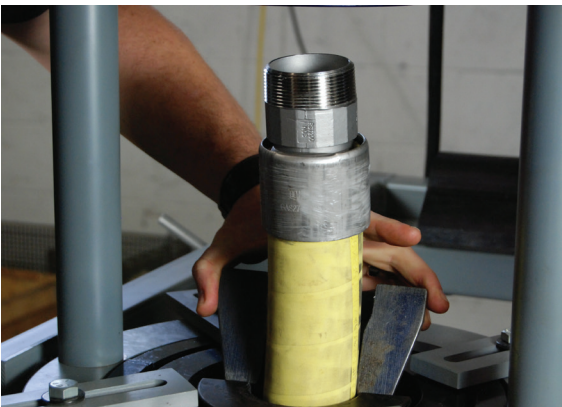

Insert the hose with fittings through the bottom of the ram (between the die holders) to allow enough room to install the die halves into the die holder.

8

Install spacer ring over threads of stem and rest on top of ferrule.

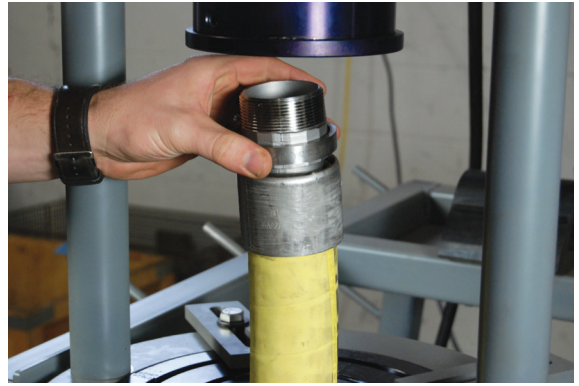

9

Install the proper pusher onto the stem. (Reference the chart for proper pusher selection)

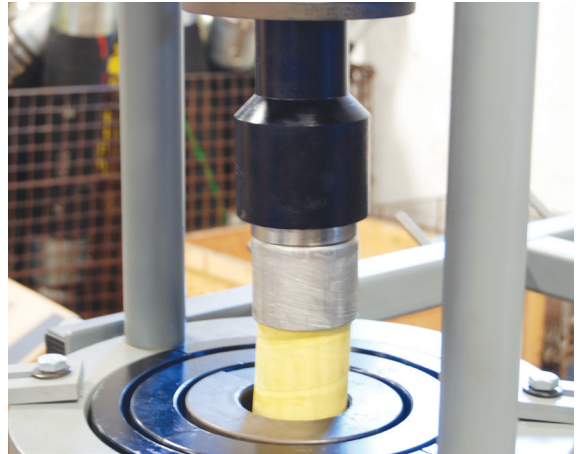

10

"Jog" the ram by quickly depressing and releasing the "on" button on the remote control switch, (or by depressing the foot pedal) until the ferrule enters the opening of the die. Go slowly as the ferrule enters the die, making sure that the end of the ferrule does not contact the face of the die.

Make sure that the stem and ferrule are forced securely against the pusher until the swaging process has begun.

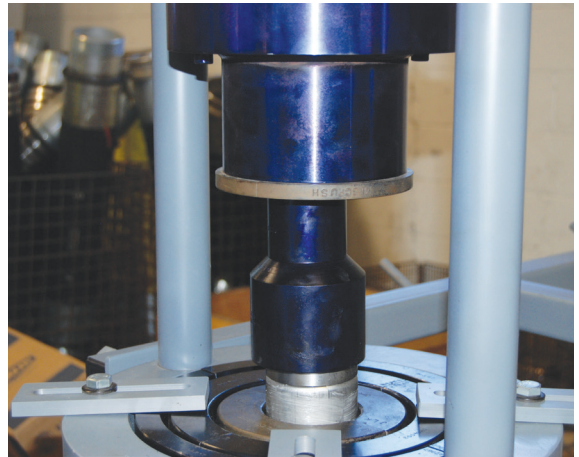

11

To complete the swaging process, depress and hold the "on" switch of the remote control unit (or depress the foot pedal). Once the ferrule has entered the die and starts to be reduced (approximately 1/3 of the way), it will no longer need the operator to keep it seated into the pusher. Continue the swage until the pusher meets the die.

Note: The spacer ring will enter the die.

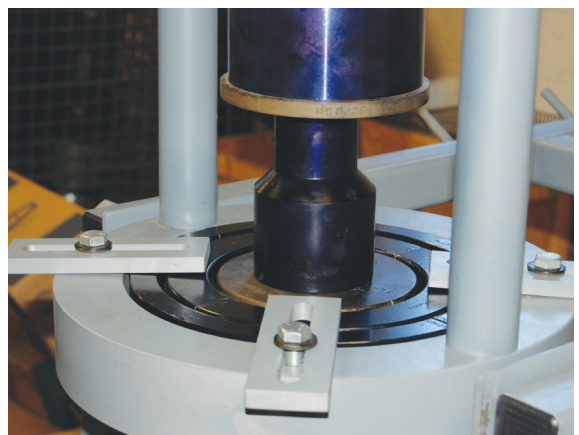

Lift the hose assembly up and remove the pusher, spacer ring and die halves from the die bed. Remove excess lubricant.

Note: If gauge reads 10,000 PSI before swaging is complete, than the ferrule or die used for that hose end may be incorrect. Contact Dixon® for further assistance.

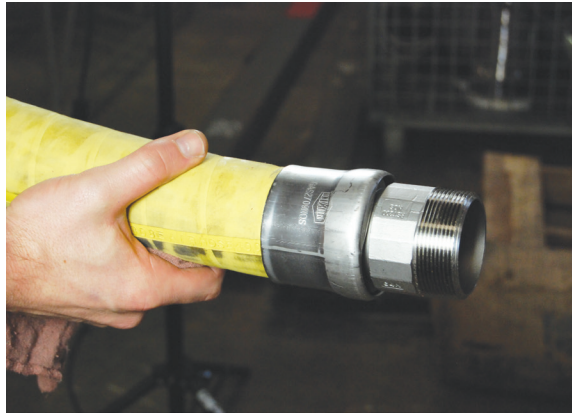

#### Pushers for RSTxxxNOS Stems

Size	Part Number
1½"	RE150PUSH
2"	D011-018
3"	RE300PUSH

Dixon® recommends that all hose assemblies be tested as recommended by the Association for Rubber Products Manufacturer's (ARPM) [ARPMINC.com](http://ARPMINC.com).



*The Right Connection®*

## 25 Ton Ram Operating Instructions

### *Section 3*

### ***External Swaging of Cam & Groove***



**Dixon**

800 High Street • Chestertown, MD 21620

ph: 877•963•4966 fax: 800•283•4966

***dixonvalve.com***

---

1

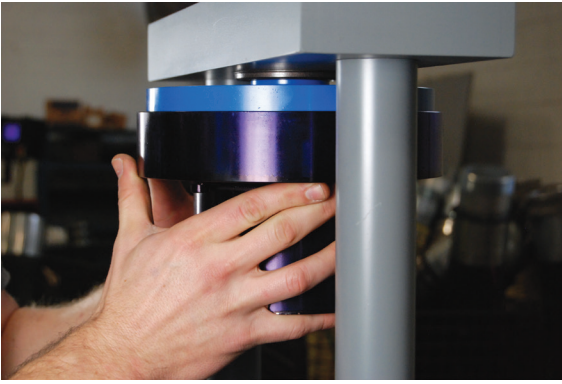

Before you begin, make sure the ram is fully re-traced, and remove the **25PUSH400** (also referred to as the pusher hat) from the main pusher plate, if installed on the ram.

2



Insert Die Holders into the Die Bed Plate as follows:

- a) **DH9-004** - Master Die Holder to hold all of the other die holders.
- b) **DH9-004-1** - Die Holder for 4" I.D. hoses only.
- c) **DH6-003** - Die Holder for 1 ¼" - 3" I.D. hose dies (fits into **DH9-004**).
- d) **DH3-001** - Die Holder for ¼" - 1" I.D. hose dies (**DH6-003** and **DH9-004** also required).

Secure the Die Holders with the tie down bars supplied

3



Accurately measure the hose O.D. with a diameter tape. Each end of the hose should be measured to guarantee the correct ferrule and die selection.

Select the proper ferrule and die based upon the hose free O.D. just measured, from the die chart.

Make sure the hose end is cut square. If the hose is to be static grounded, follow hose manufacturers procedure for proper static grounding.

4

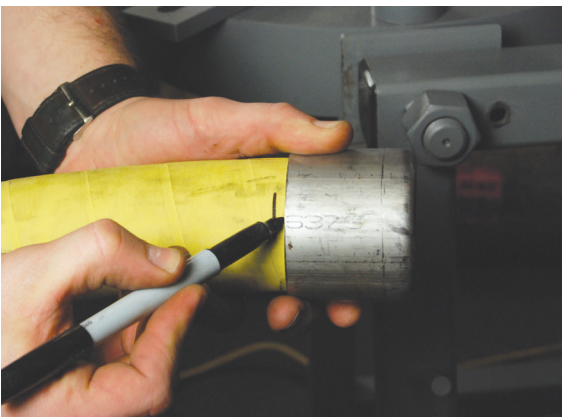

Measure the collar thickness of the stem. Slide the ferrule onto the hose. Place a mark on the hose at the end of the ferrule. Move the ferrule from the mark just made towards the end of the hose the distance of the collar thickness just measured. Place a second mark on the hose at the end of the ferrule.

## 5a

**Note:** When using the notched stem and ferrule system these guidelines must be followed:

- A. Before stem insertion, assemble the ferrule onto the stem by sliding the turned over portion of the ferrule past the notched sections of the stem collar. Rotate the ferrule 90° (¼ turn).
- B. Before starting the swaging process, make sure that the turned over portion of the ferrule and the collar are fully engaged.
- C. For "C" style couplings (requiring spacer rings), make sure that the two ring halves meet over the turned over portion of the ferrule which should be under the cam arms.



## 5b

Lubricate the Hose I.D. and the O.D. of the coupling shank with Dixon® lubricant or equivalent. Insert the cam and groove fitting with ferrule onto the hose until the ferrule is even with the mark closest to the hose end. This is the second mark made on the hose.



## 6a

For "C" Style couplings requiring spacer rings:

- a. Lubricate the inside of the die halves with Crisco® (recommended) or a high viscosity oil or heavy duty grease.

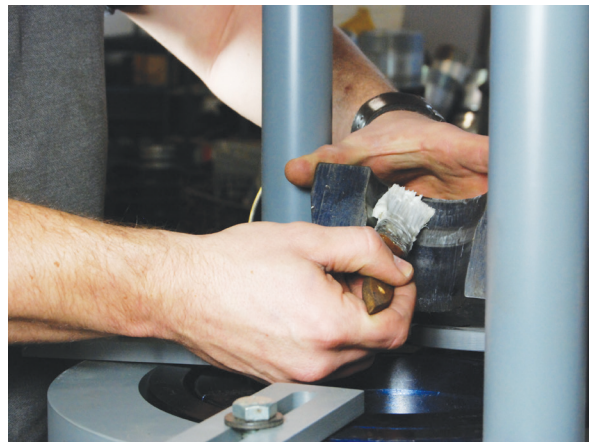

## 6b

- b. Lubricate the outside of the ferrule with Crisco® (recommended) or a high viscosity oil or heavy duty grease.





6c

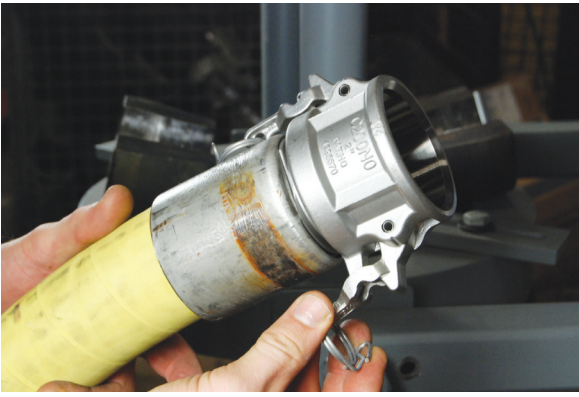

c. Release the cam arms.

6d



d. Remove the gasket from the coupler.

6e  
6f



e. Bring the hose and coupling assembly up through the base of the die bed.  
Note: One or both cam arms may close going through the die bed. If this happens, release the cam arms.

f. Put the selected die into the die bed.

6g



g. Insert the proper pusher into the coupler (reference the chart at the end of this section for proper pusher selection).

6h  
6i

- h. Bring the assembly down into the opening of the die.
- i. Jog the ram cylinder down until it meets the pusher.

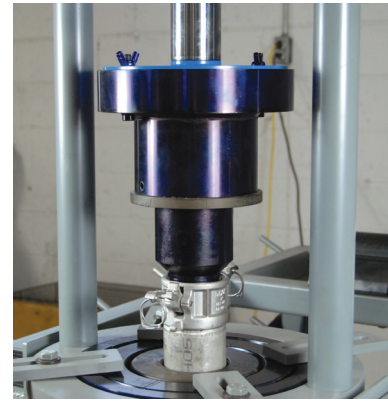

6j

- j. Hold the "on" button down (or depress the foot pedal) and continue the swage process. Release the "on" button (or foot pedal).

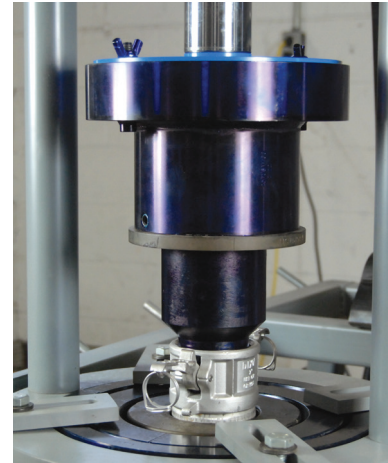

6k-end

- k. Lift the hose assembly up and remove the pusher, spacer rings and the die halves from the die bed.
- l. Lower the hose through the die bed and wipe off the excess lubricant.
- m. Re-install the gasket.



7a

For "E" Style couplings follow steps 1-5 then:

- a. Lubricate the inside of the die halves with Crisco® (recommended) or a high viscosity oil or heavy duty grease.



7b



- b. Lubricate the outside of the ferrule with Crisco® (recommended) or a high viscosity oil or heavy duty grease.

7c-d



- c. Bring the hose and coupling assembly up through the base of the die bed.
- d. Put the selected die into the die bed.

7e-f



- e. Install the proper pusher over the adapter (reference the chart at the end of this section for proper pusher selection).
- f. Bring the assembly down into the opening of the die.

7g



- g. Jog the ram cylinder down until it meets the pusher. Make sure that the cylinder plate contacts the pusher flush.

## 7h

h. Holding the hose and coupling up against the pusher hold the "on" button down (or depress the foot pedal) until the ferrule enters the opening of the die. Once the ferrule has entered the die and started to be reduced (approximately 1/3 of the way) it will no longer need the operator to keep it seated into the pusher. Continue the swage process until the pusher meets the die face. Release the "on" button (or foot pedal).

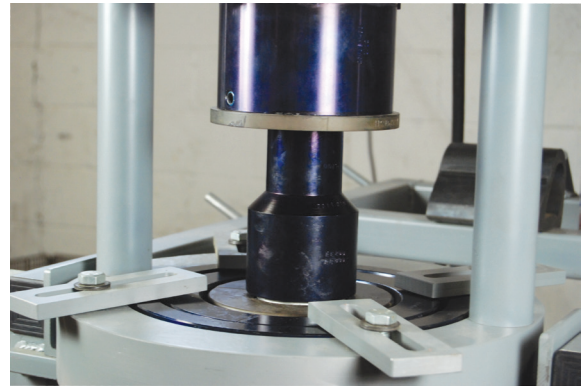

## 7i

i. Lift the hose assembly up and remove the pusher, and die halves from the die bed.

Note: If the gauge reads 10,000 PSI before swaging is complete, stop. The ferrule or die used for that hose end may be incorrect. Contact Dixon® for further assistance.



## Pushers and Spacer Rings For Cam & Groove

Size	Description	Part Number
1"	Type "E" pusher Type "C" pusher	<i><b>RE100PUSH</b></i> <i><b>RC100PUSH</b></i>
1½"	Type "E" pusher Type "C" pusher Spacer ring	<i><b>RE150PUSH</b></i> <i><b>RC150PUSH</b></i> (2 pieces) <i><b>150CGSPACE</b></i>
2"	Type "E" pusher Type "C" pusher	<i><b>D011-018</b></i> <i><b>D011-018</b></i>
3"	Type "E" pusher Type "C" pusher	<i><b>25PUSH300E</b></i> <i><b>D011-018</b></i>
4"	Type "E" pusher Type "C" pusher	<i><b>25PUSH400E</b></i> <i><b>25PUSH400C</b></i>

**Note:** Spacer rings are to be used with Type "C" couplings **ONLY**.  
**DO NOT** use spacer rings with Type "E" couplings, or bodily injury may result.

Dixon® recommends that all hose assemblies be tested as recommended by the Association for Rubber Products Manufacturer's (ARPM) [ARPMINC.com](http://ARPMINC.com).



*The Right Connection®*

## 25 Ton Ram Operating Instructions

### *Section 4*

### ***Converting from Swaging to Expansion***



**Dixon**

800 High Street • Chestertown, MD 21620

ph: 877•963•4966 fax: 800•283•4966

***dixonvalve.com***

1

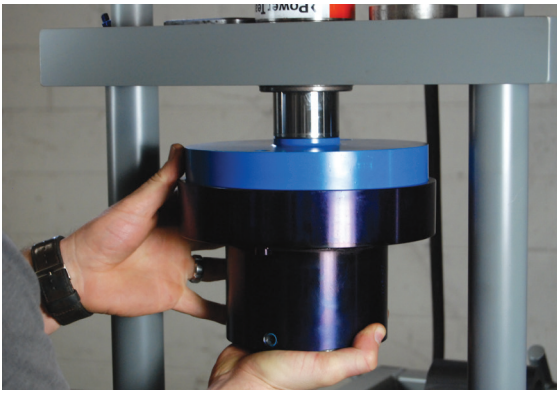

Before you begin make sure the Ram is fully retracted. Remove the **25PUSH400** (also referred to as the pusher hat) from the main pusher plate, if installed on the Ram.

2

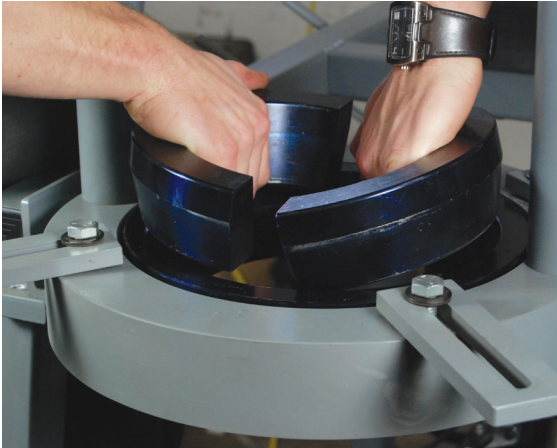

Loosen the keeper plate bolts, and remove all die holders.

3



Install the retaining bolt with washer into hole of the main Ram pusher plate (**25T5**).

4



Laying the **25IXATTACH** on it's side, move the guide plate to the center. Slide the retaining collar up until it contacts the guide plate. Tighten the set screw in the retaining collar. Stand the **25IXATTACH** up so that the end with the slot is on top.

5

Install the **25IXATTACH** by aligning the large hole with the slotted guide to the retaining bolt and washer. When installed the **25IXATTACH** will hang freely.



6

While lifting up on the **25IXATTACH**, tighten the bolt by hand in the main Ram pusher plate until it is snug.

Note: To make this step easier, stand in front of the ram and place one foot on the cross bar closest to you. Place your knee under the **25IXATTACH** and lift up. Tighten the bolt by hand until it is snug.



7

Install Die Holder **DH9-004**.

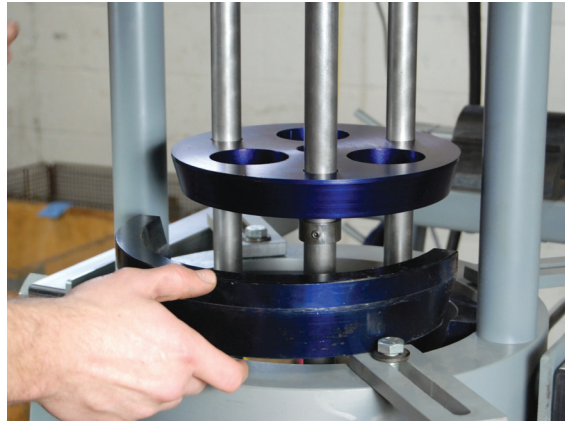

8

Loosen the retaining collar and allow the guide plate to slide down and fit into the die holder. Secure die holder and guide plate with keeper plates. Tighten evenly or else the Ram will jam.

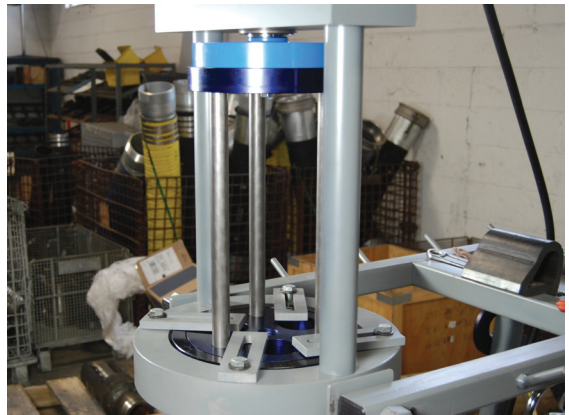



9



Remove the safety bolts behind the 1" nuts. Loosen the left 1" nut (when facing ram), then the right 1" nut (when facing ram). If this sequence is reversed (right, then left) the cylinder will rotate backwards on its own.

10a

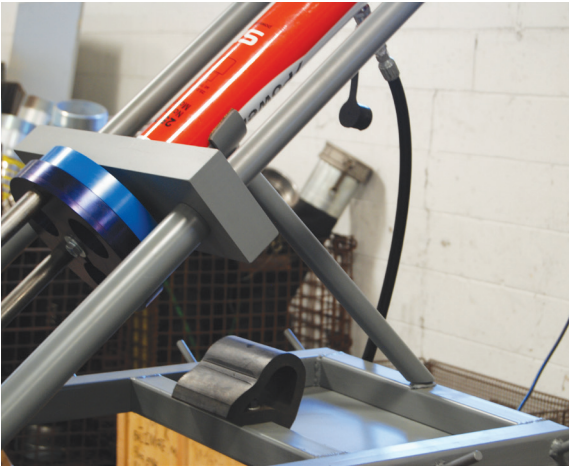

There are two options for positioning the ram for internal expansion:

Install the 45° angle bracket.

10b



Lower the Ram carefully until it rests on the bracket. You are now ready to internally expand.

**CAUTION!** The ram is extremely heavy. It may be necessary to have 2 people (1 on each side) to lower the ram. 

11



Option #2 - Do not install the 45° bracket.

Lower the Ram completely until it rests on the safety bumper. You are now ready to internally expand.

**CAUTION!** The ram is extremely heavy. It may be necessary to have 2 people (1 on each side) to lower the ram. 



*The Right Connection®*

## 25 Ton Ram Operating Instructions

### *Section 5*

### ***Internal Expansion of Steel & Stainless Steel Stems***

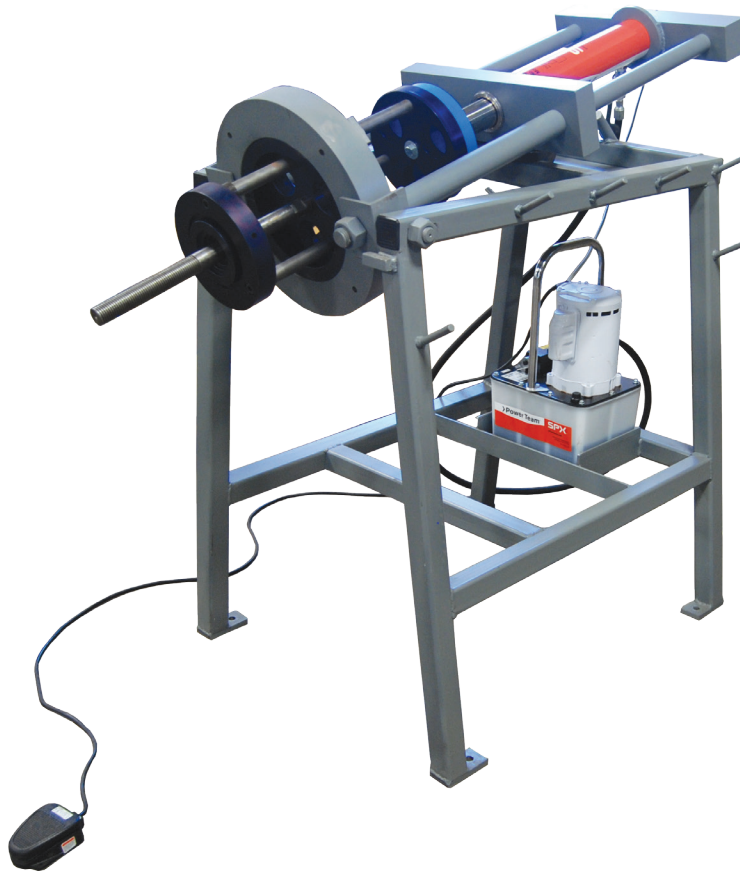

**Dixon**

800 High Street • Chestertown, MD 21620

ph: 877•963•4966 fax: 800•283•4966

***dixonvalve.com***

1

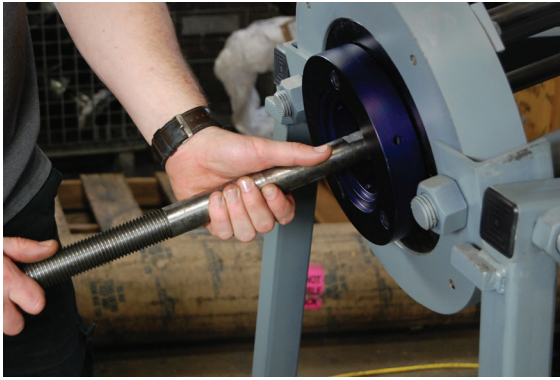

(Refer to Converting Swaging to Expansion section). Before you begin make sure the ram is fully retracted. Select the proper pull rod.

- For 1" thru 1½" use part number **25RODSMALL**
- For 2" thru 4" use part number **25RODLARGE** (note that picture is showing **25RODLARGE**)

Screw the short threaded end of the rod into the face plate of the **25IXATTACH**.

2



Select the corresponding adapter plate(s) for the size and type of fitting you are installing. The 2" thru 4" adapters have two recesses. The small diameter recess is to be used with stems having NPT\*, Victaulic or a plain end. The larger diameter recess is used for stems with the "Heavy Duty/California Style" end. \* See note on page 4.

3

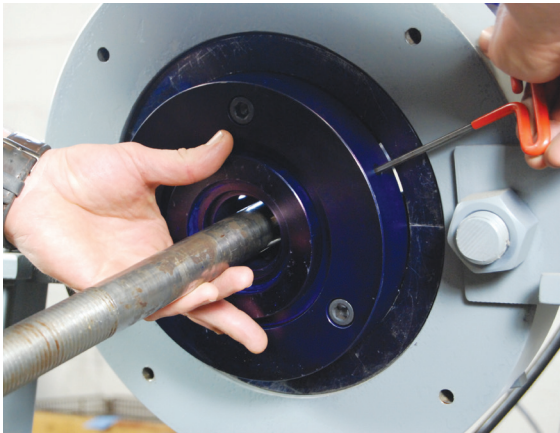

Ensuring that the recesses are facing outward towards the operator, slide the adapter plate over the pull rod until it reaches the base of the **25IXATTACH**. Tighten the set screws to secure the adapter.

4a



Lubricate the I.D. of the stem with Crisco® (recommended) or a high viscosity oil or heavy duty grease.

## 4b

Lubricate the O.D. of the small half (tapered end) of the corresponding IX plug with Crisco® (recommended) or a high viscosity oil or heavy duty grease.



## 4c

Slide the stem over the pull rod and into the recess of the adapter plate with the connection side of the stem facing the ram. Screw on (or slide) the IX plug, small end first, onto the pull rod and into the shank of the stem. For 2" and above screw the retaining nut on until it contacts the plug. Note: **25RODLARGE** is shown. Move the stem slightly to allow for slack and hand tighten the plug or nut until it is snug. Lubricate the rest of the O.D. of the plug.

**Hint:** When doing more than 1 hose assembly of the same I.D. size take the time to screw the pull rod further into the face plate of the **25IXATTACH**. This will allow for a shorter cycle time.



## 5

Accurately measure the hose O.D. with a diameter tape. Select the correct IX ferrule from the DPL based upon the hose O.D. just measured.

**Note:** Always measure both hose ends for accurate ferrule selection.



## 6

Make sure the hose end is cut square. Slide the ferrule over the hose until the turned over end of the ferrule contacts the end of the hose. Place a mark on the hose at the junction of the ferrule and hose. Move the ferrule away from the hose end  $\frac{1}{4}$ " and place another mark at the junction of the hose and ferrule. This will ensure that the proper rubber displacement or pocket is maintained during the expansion process.



7



Slide the hose with the ferrule on over the shank until the ferrule contacts the shoulder of the stem. Make sure you align the ferrule with the second mark from step 6. Make sure the pocket has been maintained. Important! If there is an insufficient pocket for the rubber to displace into, damage may occur to the stem, ferrule and/or hose.

8

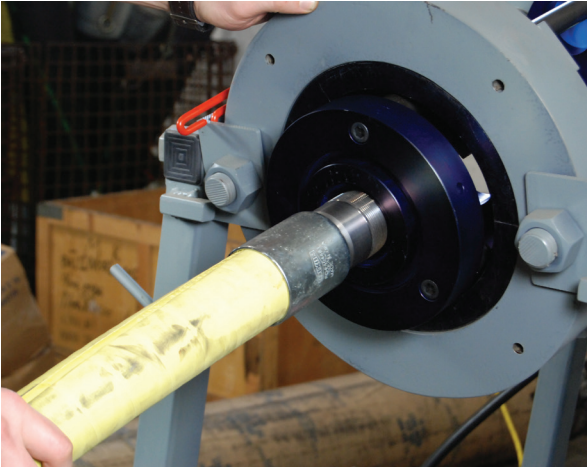

While holding the hose and ferrule firmly against the stem shoulder, engage the Ram by stepping on the foot pedal (or depressing the "ON" button on the remote control.) The internal expansion operation is complete when the hose and stem assembly is pushed completely over the internal expansion plug. Release foot pedal or "ON" switch.

Note: If the gauge reads 10,000 PSI before internal expansion is complete, stop. Contact Dixon® for further assistance. During internal expansion never stand directly in front of the Ram. Visually inspect the coupling and clean excess lubricant from the stem I.D.

Assembly procedure for 2½" threaded male stems:

In order to prevent possible thread collapse on 2½" Male NPT Stems during installation, it is recommended that a female threaded adapter be installed prior to installation. The adapter part # is **M011-384** for the 2½" male stem. Following is the procedure for installation:

1. Lubricate stem I.D. and small end of expansion plug.
2. Thread **M011-384** onto threads of the male stem hand tight ONLY!
3. Slide stem over pull rod thread adapter end first.
4. Seat **M011-384** onto OUTER recess of the adapter.
5. Follow normal IX procedure.
6. When the assembly is removed from the pull rod, remove **M011-384** and clean the stem I.D. of excess lubricant.

If you have any questions, please contact our Engineering Department.

Dixon® sells steel and stainless steel and internal expansion fittings. Verify that the correct plug and adapter plates are being used when installing fittings. Also note that with food grade fittings a different lubricant may be needed. If you need assistance please contact your Dixon® representative or call any Dixon® branch.

Dixon® recommends that all hose assemblies be tested as recommended by the Association for Rubber Products Manufacturer's (ARPM) ARPMINC.com.

# Typical Setup - 25 Ton Ram, Internal Expansion

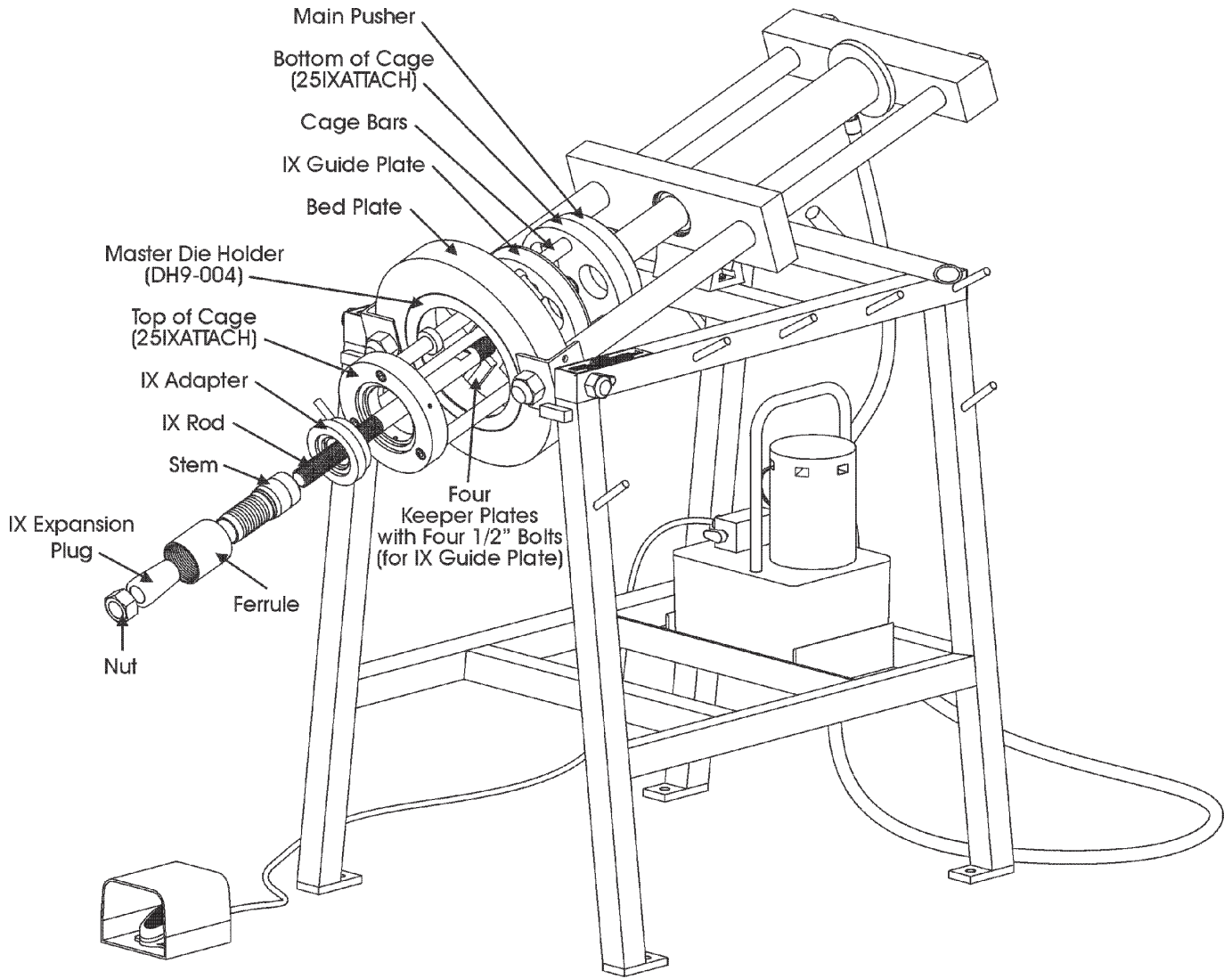



*The Right Connection®*

## 25 Ton Ram Operating Instructions

### *Section 6*

# ***Internal Expansion of Holedall H-520 Series Couplings***



**Dixon**

800 High Street • Chestertown, MD 21620

ph: 877•963•4966 fax: 800•283•4966

***dixonvalve.com***

1

Before you begin, make sure the Ram is fully retracted. Install the Holedall Petroleum Thrust Plate Adapter (**25ROSTPA**) to the end of the **25IXATTACH** with set screws. Select the proper Pull Rod.

For  $\frac{5}{8}$ " and  $\frac{3}{4}$ " use **25ROSTROD** screwed together with **25ROSTADP**.

For 1" thru 1 $\frac{1}{2}$ " use **25RODSMALL**.

For 2" thru 4" use **25RODLARGE**.

Screw the short threaded end of the rod into the face plate of the **25IXATTACH**.

Note: Picture shows **25RODLARGE**.

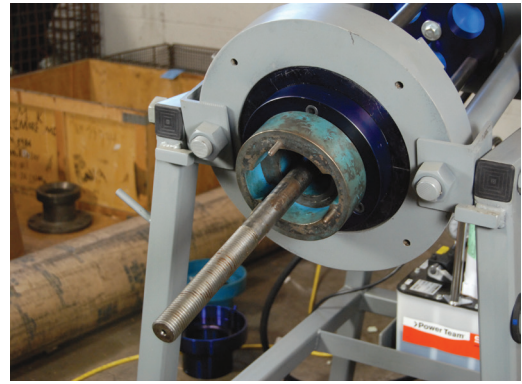

2

Select the corresponding thrust plate for the size fitting that you are installing. Ensuring that the recess is facing outward towards the operator, slide the thrust plate over the pull rod until it reaches the **25ROSTPA**. Align the holes in the thrust plate over the pins. Tighten the wing nut to lock it in place.

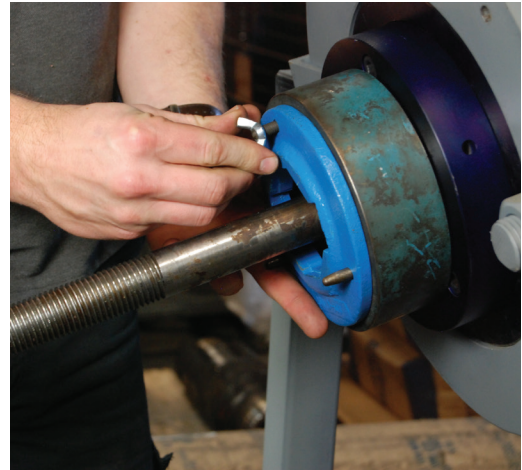

3

Slide the stem over the pull rod and into the recess of the thrust plate with the connection side of the stem facing the ram. For male stems, insert the hex into the recess of the thrust plate. For female stems, insert the first hex into the thrust plate so that it goes all the way through, so that the second hex will fit into the recess of the thrust plate.

Note: There is no need to lubricate the plug or stem. The stems are pre-lubricated at the factory .



4

Screw (or slide) the IX plug, small end first, onto the pull rod and into the shank of the stem. For 2" and above screw the retaining nut on until it contacts the plug. Move the stem slightly to allow for slack and hand tighten the plug or nut until it is snug.

Hint: When doing more than 1 hose assembly of the same ID size take the time to screw the pull rod further into the face plate of the **25IXATTACH**. This will allow for a shorter cycle time.





5



Accurately measure the hose O.D. with a diameter tape. Select the correct Holedall Petroleum ferrule from the DPL based upon the hose O.D. just measured.

Note: Always measure both ends of the hose for accurate ferrule selection.

6



Make sure the hose end is cut square. Measure and mark the hose in accordance with the provided Insertion Dimension chart (see page 3). This will ensure that the proper rubber displacement "pocket" is maintained when proceeding to Step 7.

7

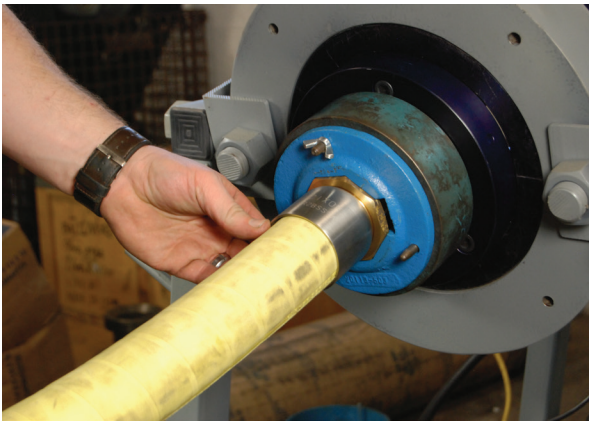

Ensuring that the end of the ferrule is aligned with the mark from Step 6, slide the hose with ferrule over the shank until the ferrule contacts the shoulder of the stem. Check to see if the proper pocket is maintained.

Important! If there is an insufficient pocket for the rubber to displace into, damage may occur to the stem, ferrule and/or hose.

8



While holding the hose and the ferrule firmly against the stem shoulder, engage the Ram by stepping on the foot pedal, or depressing the "ON" button on the remote control. The internal expansion operation is complete when the hose and stem assembly is pushed completely over the internal expansion plug. Release the foot pedal or "ON" switch. Note: If the gauge reads 10,000 PSI before internal expansion is complete, stop. Contact Dixon® for further assistance.

**During internal expansion never stand directly in front of the Ram.** Visually inspect the coupling and clean excess lubricant from the stem ID. Dixon® recommends that all hose assemblies be tested as recommended by the Association for Rubber Products Manufacturer's.

# Insertion Dimensions for Rostra Fittings

<u>Ferrule Sizes</u>	<u>Insertion Length</u>
1"	25/32"
1¼"	25/32"
1⅜"	25/32"
1½"	1-1/32"
2"	1-19/32"
2½"	2¼"
3"	2¾"
4"	3-7/32"

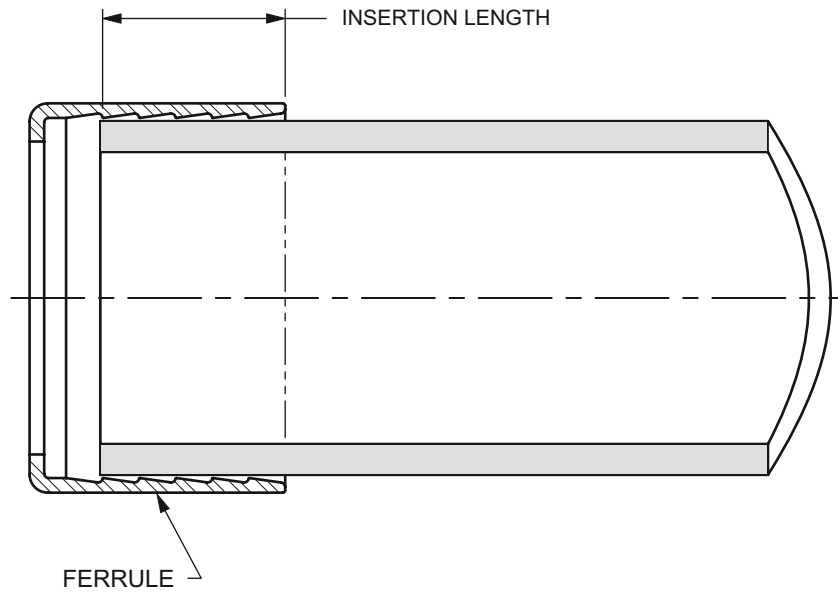



*The Right Connection®*

## 25 Ton Ram Operating Instructions

### *Section 7*

### ***Product Updates & Notes***

#### **Dixon**

800 High Street • Chestertown, MD 21620

ph: 877•963•4966 fax: 800•283•4966

***dixonvalve.com***

# ENGINEERING BULLETIN

## PRODUCT UPDATE

**Date:** October 28, 1997

**Part Number:** **IXM40**, 2½" Internal Expansion Male Stem

**Update:** Use **M011-384** Thread Adapter for assembly

**Reason:** Possible thread collapse during expansion process

In order to prevent possible thread collapse on **IXM40's** during installation, it is recommended that a female threaded adapter be installed prior to installation. The adapter part # is **M011-384**. Follow this procedure for installation:

1. Lubricate stem ID and small end of expansion plug.
2. Thread **M011-384** onto threads of **IXM40** hand tight ONLY!
3. Slide stem over pull rod thread adapter end first.
4. Seat **M011-384** onto OUTER recess of **25ADAPT250**.
5. Follow normal IX procedure.
6. When the assembly is removed from the pull rod, remove **M011-384** and clean the stem ID of excess lubricant.

# ENGINEERING BULLETIN

## PRODUCT UPDATE

**Date:** October 6, 1998

**To:** All 25 Ton Ram Customers

**From:** Dixon Engineering

**Part Number:** 4" Swaging and 4" IX Stems

In an effort to keep you up to date on installation procedures for the 25 Ton Ram, please review the following information regarding Swaging of 4" hose and the Internal Expansion of 4" Male Threads.

### Swaging:

Dixon® recently received a report of a coupling retention situation using 4" Swaged Cam & Groove with Goodyear's Orange Flexwing Hose and 4" TM Holedall Stems on Boston Royalflex 1196 Hose. The fittings were installed using a 25 Ton Ram. Coupling movement occurred.

Both of the situations were corrected by using a die holder longer than the standard die holder (**DH9-004**). The new longer die holder is part number **DH9-004-1**.

It has been Dixon®'s policy that when applications arise where an improvement to a system is warranted, it notifies its customer base. Therefore, it is our recommendation that when doing 4" Swaged Cam & Groove or Standard Holedall Stems, you use the new 4" Die Holder. This is our first experience with any 4" Swage type fittings assembled with the 25 Ton Ram not performing as intended. It is important to note that it is only on the 25 Ton Ram that this new Die Holder is required.

The new Die Holder is to be used in conjunction with the **DH9-004** currently in use for 4" stems. The **DH9-004** is still needed to do smaller ID hoses, as well as with the **25IXATTACH**. The **DH9-004-1** is only for 4" ID hose.

### Internal Expansion:

Dixon® recently received a report of a situation concerning the installation of 4" Internal Expansion Male Threaded Stems (**IXCM64**). The fittings were installed using a 25 Ton Ram with the **25IXATTACH**. At the base of the **25IXATTACH** is the 4" Adapter. Over time this adapter end can wear. This wear can cause the 4" **IXM64** stem to collapse at the threads during the installation process. This happens because even pressure is not applied on the threads as the stem is being expanded.

The situation can be corrected by using an adapter designed for the 4" fittings. This new part number is **M011-385**. Unlike the adapter designed for the **IXM40's**, this adapter is recommended only if the **25IXATTACH** has a worn plate. It is not a requirement that it be purchased to do 4" IX Stems.



*The Right Connection®*

## 25 Ton Ram Operating Instructions

### *Section 8*

### ***Sample Forms***

#### **Dixon**

800 High Street • Chestertown, MD 21620

ph: 877•963•4966 fax: 800•283•4966

***dixonvalve.com***

**DIXON® HOLEDALL TYPE  
PERMANENTLY ATTACHED COUPLING TEST**

ENGINEERING REPORT No. \_\_\_\_\_

<b>SUBJECT:</b>		
<b>HOSE:</b>	<b>WORKING PRESSURE</b> _____ <b>TEST PRESSURE</b> _____ <b>BURST PRESSURE</b> _____	
	<b>"A" End</b>	<b>"B" End</b>
<b>HOSE O.D. (free)</b>		
<b>HOSE O.D. (over stem)</b>		
<b>STEM</b>		
<b>FERRULE</b>		
<b>DIE</b>		
<b>MULCORAM</b>		
<b>PUSHER</b>		
<b>FORCE (In PSI)</b>		
<b>REDUCED LENGTH</b>		
<b>HOSE WALL (free)</b>		
<b>HOSE O.D REDUCED</b>		
<b>STEM — MEAN O.D</b>		
<b>HOSE WALL REDUCED</b>		
<b>REDUCTION</b>		
<b><u>REMARKS:</u></b>		

**COUPLED BY** \_\_\_\_\_

**DATE** \_\_\_\_\_

**APPROVED BY** \_\_\_\_\_

**COMPANY** \_\_\_\_\_

# HYDROSTATIC TEST REPORT

ENGINEERING REPORT No. \_\_\_\_\_

SUBJECT:			
PRESSURE PSIG	TIME MIN.	COMMENTS	
		"A" END	"B" END
<b>REMARKS:</b>			

TEST CONDUCTED BY \_\_\_\_\_ DATE \_\_\_\_\_

APPROVED BY \_\_\_\_\_

COMPANY \_\_\_\_\_





*The Right Connection®*

## 25 Ton Ram Operating Instructions

*Section 9*

***Parts List***

**Dixon**

800 High Street • Chestertown, MD 21620

ph: 877•963•4966 fax: 800•283•4966

***dixonvalve.com***

## 25 Ton Ram

25 TONRAM

Mulcoram includes 115V pump, 10,000 PSI hose, gauge

### External Swage Attachments

Please note that on some sizes, more than two attachments may be necessary. Read carefully through all descriptions to determine which attachments are needed for your applications. Please consult Dixon® if you need more information.

25PUSH400	4" pusher for external swage (pusher hat) <b>(Needed for all sizes)</b>
25PUSH300	3" pusher for external swaging
25PUSH250	2½" pusher for external swaging
25PUSH200	2" pusher for external swaging
25PUSH150	1½" pusher for external swaging
25PUSH125	1¼" pusher for external swaging
DH9-004-1	Die holder needed for 4" only (must use with <b>DH9-004</b> )
DH9-004	Die holder needed for all sizes
DH6-003	Die holder needed for 1-1/4" to 3"
RST300SPACE	3" spacer ring for NOS ferrules (must use with <b>25PUSH300E</b> )
RST200SPACE	2" spacer ring for NOS ferrules (must use with <b>D011-018</b> )
RST150SPACE	1½" spacer ring for NOS ferrules (must use with <b>RE150PUSH</b> )

**Swage dies not included**

## **25 Ton Ram**

### *Equipment to Swage 1¼" to 4" ID Hose (cont.)*

<b>RN150NOPUSH</b>	1½" pusher for notched turned back nipple
<b>RN200NOPUSH</b>	2" pusher for notched turned back nipple
<b>RN300NOPUSH</b>	3" pusher for notched turned back nipple
<b>RN400NOPUSH</b>	4" pusher for notched turned back nipple
<b>M011-331</b>	Pusher for female Holedall ( <b>TF16WF1-80</b> )
<b>M011-332</b>	Pusher for female Holedall ( <b>TF16WF3-80</b> )
<b>M011-333</b>	Pusher for female Holedall ( <b>TF16WF3-80</b> )
<b>25PUSH125-MOD</b>	Pusher for 1¼" female Holedall
<b>25PUSH200-MOD</b>	Pusher for 2" female Holedall

## **Unirange External Swage**

*Equipment to Install ¼" to 1" Unirange Couplings*

<b>DH9-004</b>	Die holder needed for all Sizes
<b>DH6-003</b>	Die holder for all Sizes 3" and below
<b>DH3-001</b>	Die holder needed for all Sizes 1" and below
<b>25PUSH100</b>	Pusher adapter ( <b>needed for all sizes below</b> )
<b>M011-327</b>	Pusher for <b>16P1</b>
<b>M011-328</b>	Pusher for <b>16P2, R16P1620</b>
<b>M011-329</b>	Pusher for <b>16P3</b>
<b>M011-330</b>	Pusher for <b>16P4, R16P1770</b>
<b>M011-320</b>	Pusher for <b>12P1</b>
<b>M011-321</b>	Pusher for <b>12P2</b>
<b>M011-322</b>	Pusher for <b>12P3</b>
<b>M011-313</b>	Pusher for <b>8P1</b>
<b>M011-314</b>	Pusher for <b>8P2</b>
<b>M011-315</b>	Pusher for <b>8P3</b>
<b>M011-310</b>	Pusher for <b>6P1</b>
<b>M011-311</b>	Pusher for <b>6P2</b>
<b>M011-312</b>	Pusher for <b>6P3</b>
<b>M011-306</b>	Pusher for <b>4P1</b>
<b>M011-307</b>	Pusher for <b>4P2</b>
<b>M011-308</b>	Pusher for <b>4P3</b>
<b>AKPUSH</b>	Pusher for Air King® ½" - 1"

***Swage dies not included***

## **25 Ton Ram**

### *Equipment to Swage 1" through 4" Cam & Groove*

<b>DH9-004-1</b>	Die holder needed for 4" only (must be used with <b>DH9-004</b> )
<b>DH9-004</b>	Die holder needed for all sizes
<b>DH6-003</b>	Die holder needed for 3" and below
<b>DH3-001</b>	Die holder needed for 1" and below
<b>25PUSH400C</b>	Pusher for 4" C
<b>25PUSH400E</b>	Pusher for 4" E
<b>25PUSH300E</b>	Pusher for 3" E
<b>D011-018</b>	Pusher for 2" C, 2" E and 3" C
<b>RC150PUSH</b>	Pusher for 1½" C (two parts)
<b>RE150PUSH</b>	Pusher for 1½" E
<b>RC100PUSH</b>	Pusher for 1" C
<b>RE100PUSH</b>	Pusher for 1" E
<b>150CGSPACE *</b>	Spacer rings for 1½" C
<b>100CGSPACE *</b>	Spacer rings for 1" C

***Swage dies not included***

\* Future designs may not require spacer rings. Contact Dixon® for more information.

## **25 Ton Ram**

### *Equipment to Internally Expand Steel IX*

<b>25IXATTACH</b>	Internal expanding attachment for 25 Ton Ram includes 4" internal expanding adapter <b>(needed for all sizes)</b>
<b>DH9-004</b>	Die holder/ adapter for <b>25IXATTACH (needed for all sizes)</b>
<b>25RODLARGE</b>	IX rod for 2" - 4" hose
<b>25RDLG-A</b>	Large rod for only <b>25TONRAM</b>
<b>25RDLG-B</b>	Nut only for 15 & 25 TON RAMS
<b>25RODSMALL</b>	IX rod for 1" to 1½" hose
<b>25RDSML-A</b>	Small pull rod
<b>25RDSML-B</b>	Small pull rod adapter
<b>25RDSML-C</b>	Nut for small rod
<b>M011-385</b>	4" IX adapter (IXM64 only)
<b>25ADAPT300</b>	3" IX adapter
<b>25ADAPT250</b>	2½" IX adapter
<b>M011-384</b>	2½" IXM40 adapter (must be used with <b>25ADAPT250</b> )
<b>25ADAPT200</b>	2" IX adapter
<b>25ADAPT150</b>	1½" IX adapter
<b>25ADAPT125</b>	1¼" IX adapter
<b>25ADAPT100</b>	1" IX adapter
<b>IXPLUG400</b>	4" IX plug for steel & Holedall Petroleum fittings
<b>IXPLUG300</b>	3" IX plug for steel & Holedall Petroleum fittings
<b>IXPLUG250</b>	2½" IX plug for steel & Holedall Petroleum fittings
<b>IXPLUG200</b>	2" IX plug for steel & Holedall Petroleum fittings
<b>IXPLUG150</b>	1½" plug for steel & Holedall Petroleum fittings
<b>IXPLUG125</b>	1¼" IX plug for steel & Holedall Petroleum fittings
<b>IXPLUG100</b>	1" IX plug for steel & Holedall Petroleum fittings

## **25 Ton Ram**

### *Equipment to Internally Expand Flow Chief Food Grade Fittings*

<b>25IXATTACH</b>	Internal expanding attachment for 25 Ton Ram includes 4" internal expanding adapter for male NPT <b>(needed for all sizes)</b>
<b>DH9-004</b>	Die holder <b>(needed for all sizes)</b>
<b>25RODLARGE</b>	IX rod for 2" - 4" hose
<b>25RDLG-A</b>	Large rod for only <b>25TONRAM</b>
<b>25RDLG-B</b>	Nut only for 15 & 25 TON RAMS
<b>25RODSMALL</b>	IX rod for 1" to 1½" hose
<b>25RDSML-A</b>	Small pull rod
<b>25RDSML-B</b>	Small pull rod adapter
<b>25RDSML-C</b>	Nut for small rod
<b>25ADAPT300</b>	3" IX adapter for male NPT
<b>25ADAPT250</b>	2 ½" IX adapter for male NPT
<b>25ADAPT200</b>	2" IX adapter for male NPT
<b>25ADAPT150</b>	1½" IX adapter for male NPT
<b>PFADAPT400</b>	4" sanitary end adapter (Tri Clover style)
<b>PFADAPT300</b>	3" sanitary end adapter (Tri Clover style)
<b>PFADAPT250</b>	2½" sanitary end adapter (Tri Clover style)
<b>PFADAPT200</b>	2" sanitary end adapter (Tri Clover style)
<b>PFADAPT150</b>	1½" sanitary end adapter (Tri Clover style)
<b>PFADAPT150-3A</b>	1½" sanitary end adapter for 3A (Tri Clover style)

## **25 Ton Ram**

### *Equipment to Internally Expand Flow Chief Food Grade Fittings (cont.)*

<b>PFACNTA400</b>	4" bevel seat Acme nut adapter ( <b>must buy PFADAPT400 to use this part</b> )
<b>PFACNTA300</b>	3" bevel seat Acme nut adapter ( <b>must buy PFADAPT300 to use this part</b> )
<b>PFACNTA250</b>	2½" bevel seat Acme nut adapter ( <b>must buy PFADAPT250 to use this part</b> )
<b>PFACNTA200</b>	2" bevel seat Acme nut adapter ( <b>must buy PFADAPT200 to use this part</b> )
<b>PFACNTA150</b>	1½" bevel seat Acme nut adapter ( <b>must buy PFADAPT150 to use this part</b> )
<b>IXFDPLG400</b>	4" food plug (for stainless steel fittings only)
<b>IXFDPLG300</b>	3" food plug (for stainless steel fittings only)
<b>IXFDPLG250</b>	2½" food plug (for stainless steel fittings only)
<b>IXFDPLG200</b>	2" food plug (for stainless steel fittings only)
<b>IXFDPLG150</b>	1½" food plug (for stainless steel fittings only)
<b>IXFDPLG287</b>	3" 3A food plug (for stainless steel fittings only)
<b>IXFDPLG187</b>	2" 3A food plug (for stainless steel fittings only)
<b>IXFDPLG137</b>	1½" 3A food plug (for stainless steel fittings only)



## **25 Ton Ram**

### *Equipment to Internally Expand Holedall Petroleum Fittings*

<b>25IXATTACH</b>	Internal expanding attachment for 25 Ton Ram includes 4" internal expanding adapter for male NPT ( <b>needed for all sizes</b> )
<b>DH9-004</b>	Die holder/adapter for <b>25IXATTACH</b> ( <b>needed for all sizes</b> )
<b>25ROSTPA</b>	Adapter plate to hold thrust plates
<b>25ROSTROD</b>	Pull rod for 5/8", 3/4" and 1" - consists of the following:
<b>25ROSTROD-A</b>	Small Holedall Petroleum pull rod
<b>25DSML-B</b>	Small pull rod adapter
<b>25RDSML-C</b>	Nut for small rod
<b>25RODLARGE</b>	Pull rod for 2" through 4" - Consists of the following:
<b>25RDLG-A</b>	Large rod for only <b>25TONRAM</b>
<b>25RDLG-B</b>	Nut only for 15 & 25 TON RAMS
<b>25RODSMALL</b>	Pull rod for 1" to 1½" - consists of the following:
<b>25RDSML-A</b>	Small pull rod
<b>25RDSML-B</b>	Small pull rod adapter
<b>25RDSML-C</b>	Nut for small rod
<b>IXPLUG400</b>	4" IX plug for steel & Holedall Petroleum fittings
<b>IXPLUG300</b>	3" IX plug for steel & Holedall Petroleum fittings
<b>IXPLUG250</b>	2½" IX plug for steel & Holedall Petroleum fittings
<b>IXPLUG200</b>	2" IX plug for steel & Holedall Petroleum fittings
<b>IXPLUG150</b>	1½" IX plug for steel & Holedall Petroleum fittings
<b>IXPLUG138</b>	1⅜" IX plug for steel & Holedall Petroleum fittings
<b>IXPLUG125</b>	1¼" IX plug for steel & Holedall Petroleum fittings
<b>IXPLUG100</b>	1" IX plug for steel & Holedall Petroleum fittings

## **25 Ton Ram**

### *Equipment to Internally Expand Holedall Petroleum Fittings (cont.)*

<b>25000HTL03</b>	1" IX plug (must use <b>25ROSTROD</b> )
<b>25000HTL02</b>	¾" IX plug (must use <b>25ROSTROD</b> )
<b>25000HTL01</b>	⅝" IX plug (must use <b>25ROSTROD</b> )
<b>25000HTL26</b>	Thrust plate for 3" aluminum H-520 style fittings
<b>25000HTL25</b>	Thrust plate for 2½" aluminum H-520 style fittings
<b>25000HTL24</b>	Thrust plate for 2" aluminum H-520 style fittings
<b>25000HTL23</b>	Thrust plate for 4" H-520 style fittings
<b>25000HTL22</b>	Thrust plate for 3" H-520 style fittings
<b>25000HTL21</b>	Thrust plate for 2½" H-520 style fittings
<b>25000HTL20</b>	Thrust plate for 2" H-520 style fittings
<b>25000HTL19</b>	Thrust plate for 1⅜" & 1½" H-520 style fittings
<b>H5211NSTADT</b>	Adapter for NST female 1" H-520 style fittings
<b>H5231NSTADT</b>	Adapter for NST female 1½" H-520 series couplings
<b>25000HTL18</b>	Thrust plate for 1¼" H-520 style fittings
<b>25000HTL17</b>	Thrust plate for 1" H-520 style fittings
<b>25000HTL16</b>	Thrust plate for 1" x 1½" H570 style fittings Thrust plate for 1" x 1 9/16" H-570 style fittings
<b>25000HTL15</b>	Thrust plate for 1" x 1-25/64" H-570 style fittings Thrust plate for 1" x 1-29/64" H-570 style fittings
<b>25000HTL14</b>	Thrust plate for ¾" H-520 style fittings
<b>25000HTL13</b>	Thrust plate for ¾" x 1-7/32" H-570/H580 fittings
<b>25000HTL12</b>	Thrust plate for ¾" x 1-9/64" H-570/H580 fittings Thrust plate for ¾" x 1-11/64" H-570/H580 fittings Thrust plate for ¾" x 1-13/64" H-570/H580 fittings
<b>25000HTL11</b>	Thrust plate for ⅝" H-570 fittings

\* Consult Dixon® for the necessary attachments to use the Scovill style plugs (1¼" - 4")

## 25 Ton Ram Parts - External Swaging

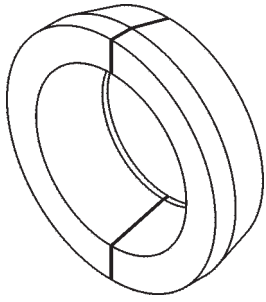

Die Holder

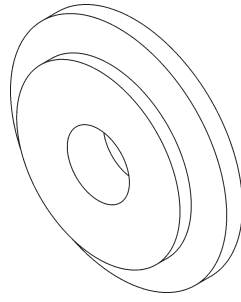

Pusher Plate

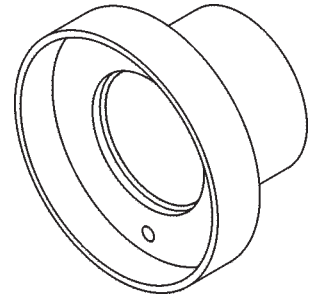

Pusher Hat (4")

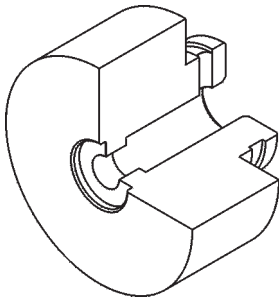

Pusher Adapter

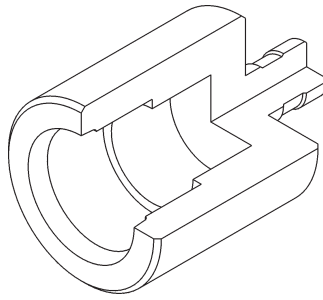

Unirange Pusher

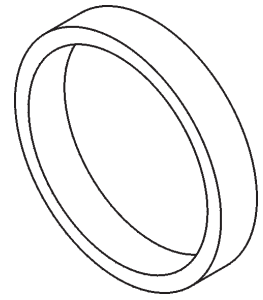

RSTXXX Spacer

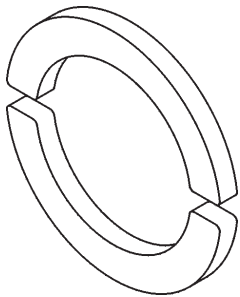

Cam & Groove Space  
Ring

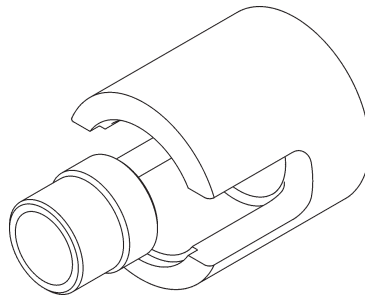

1 1/2" Cam & Groove  
Pusher

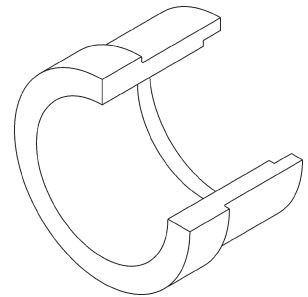

3" & 4" Cam & Groove  
Pusher

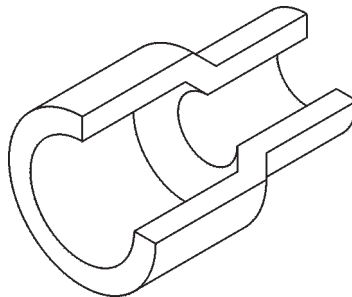

2" Type C & E Cam & Groove  
Pusher;  
3" Type C Cam & Groove Pusher

**These drawings represent the overall shape of the parts only. Please consult the complete Ram Attachments listing for specific descriptions regarding size, usage, etc.**

## 25 Ton Ram Parts - Internal Expansion

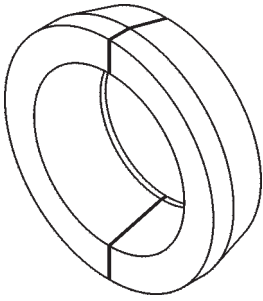

Die Holder

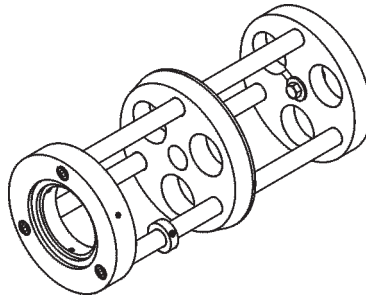

Internal Expanding Attachment

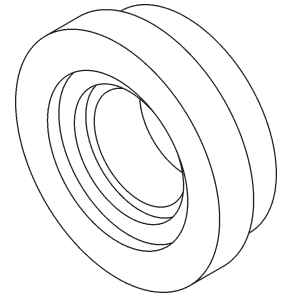

IX Adapter

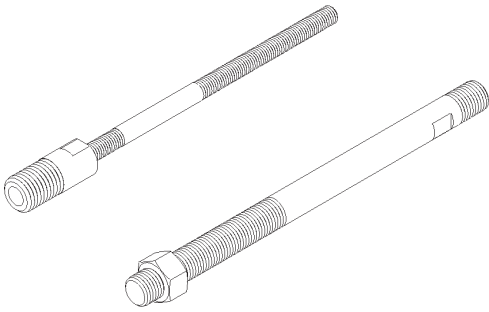

IX Pull Rods

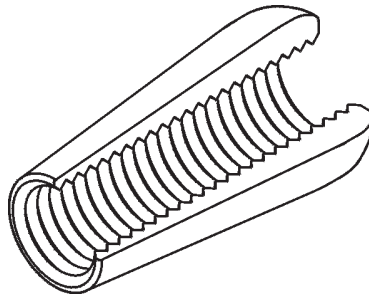

1 1/2" IX Plug

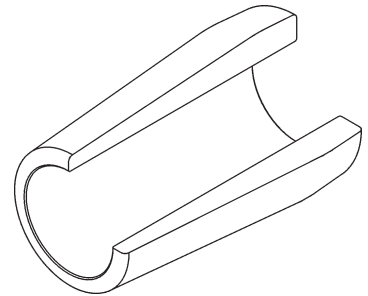

2" & larger IX Plug

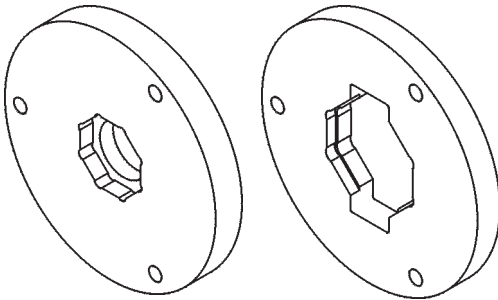

Thrust Plates

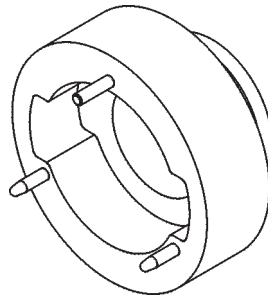

Adapter Plate for Thrust Plate

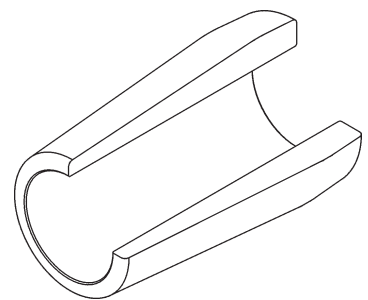

Food Plug

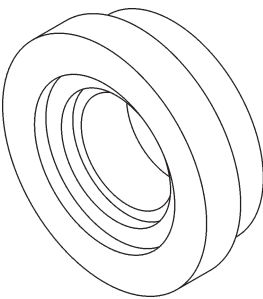

Sanitary End Adapter

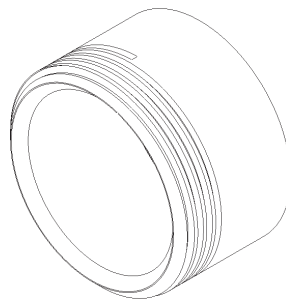

Acme Nut Adapter

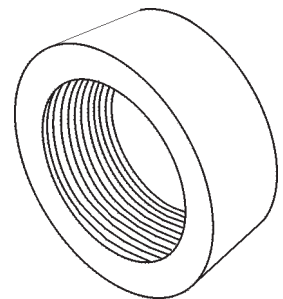

IX Male NPT Adapter

**These drawings represent the overall shape of the parts only. Please consult the complete Ram Attachments listing for specific descriptions regarding size, usage, etc.**

# PUMP INSTALLATION

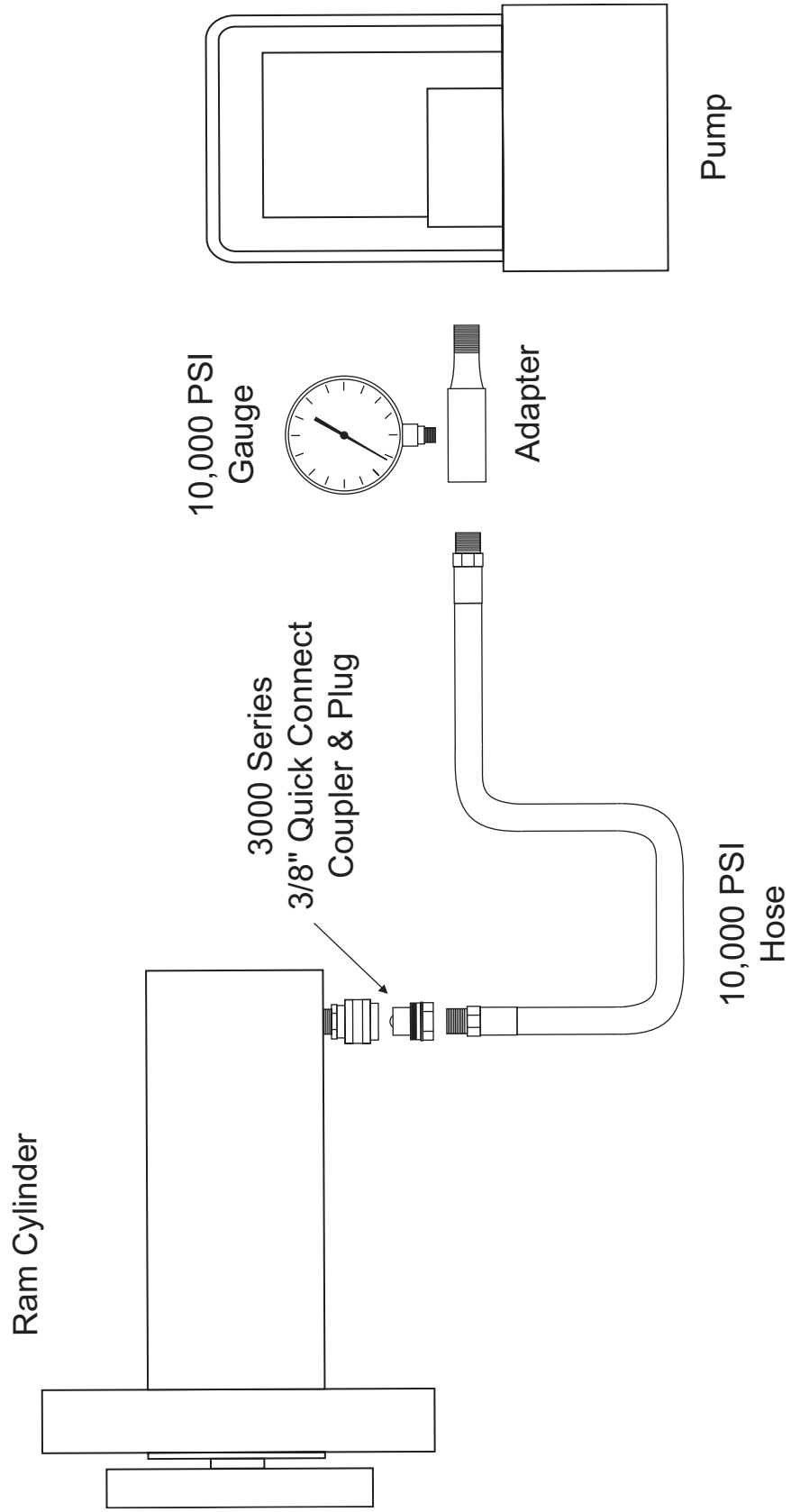

Dixon®, founded in 1916, is a premier manufacturer and supplier of hose couplings, valves, dry-disconnects, swivels, and other fluid transfer and control products. The company's global reach includes a wide range of products for numerous industries including petroleum exploration, refining, transportation, chemical processing, food & beverage, steel, fire protection, construction, mining and manufacturing. Dixon®'s strategic objective is to create solutions that make products safer, leak-free, longer lasting, and always available.

**dixonvalve.com • Customer Service: 877.963.4966**



*The Right Connection®*

**Dixon®**

800 High Street, Chestertown, MD 21620

ph 877.963.4966

fx 800-283-4966

dixonvalve.com

